

Part 1 - GENERAL

Scope

The framing shall be Metro "F" Series single glazed flushline system as manufactured by Metro Glass. Furnish all materials, labour and services for the complete fabrication, assembly and installation of aluminum framing as required based on the contract or the purchase agreement.

Work Not Included: Structural support of framing, interior building trims, and as specified by drawings and customer requirements per contract or purchase agreement.

Quality Assurance

Drawings and specification for work in this section are based upon Metro "F" Series framing system.

Design & Performance

Framing to fully comply with applicable standard specifications as typically referenced to the following requirement criteria: Air and water tightness, wind and other load resistance.

Maintenance and Warranty

Upon request, Metro will provide instructions for proper cleaning and maintenance. Metro Glass Metal Products come with two year warranty which shall begin from the day the product is shipped or from substantial completion of the installation. The warranty covers materials and workmanship as specified by drawings and customer requirements per contract or purchase agreement.

Part 2 - PRODUCTS

Materials

All materials to meet design and material specifications as applicable. Extruded aluminum shall be 6063 T6 alloy and temper. Any defects impairing strength, durability or appearance are not acceptable.

Fasteners shall be of sufficient size and strength and made of corrosion-resistant and compatible materials.

Glazing gaskets shall be extruded black santoprene designed and sized to perform their intended function.

Fabrication

Frame assembly to provide accurately fit tight hairline joints only. Extruded profiles to be of sizes and profiles indicated in the contract or the purchase agreement. Corner joints shall be secured with concealed shear blocks with fastening by means of anticorrosive steel screws, and as specified by drawings and customer requirements per contract or purchase agreement.

Finish - Anodized 6063 Material Code Identification

Exposed surfaces shall be finished as specified by customer:

Satin Clear 14 AA-M12C22A41

Satin Medium Bronze 30 AA-M12C22A44

Satin Black 29 AA-M12C22A44

Powdercoated and various other finishes (including shades of Bronze) available upon request.

Installation

Framing to be installed plumb, level and square and glazed by an experienced crew in prepared openings in accordance to the manufacturers instructions and approved shop drawings, and as specified by drawings and customer requirements per contract or purchase agreement.

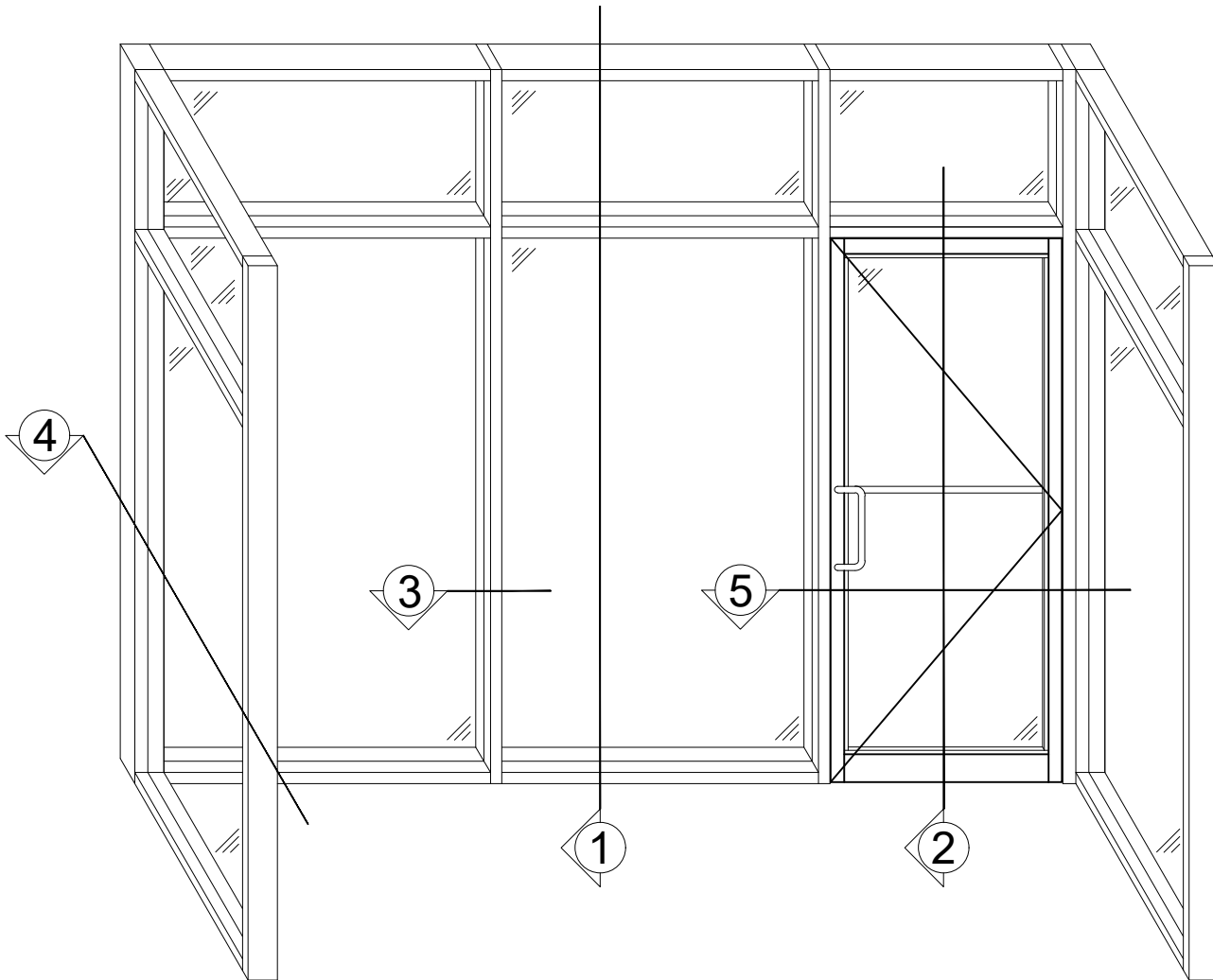

F SERIES: FLUSHLINE

A POPULAR CHOICE FOR INTERIOR APPLICATIONS.

A SINGLE GLAZED SYSTEM USED FOR VESTIBULES, OFFICE PARTITIONS
AND OTHER GLAZING NEEDS.

CAN BE FABRICATED TO SUIT MOST OPENING REQUIREMENTS.

More than 50 Years of Manufacturing Innovative Aluminum Doors, Frames, Curtain Walls, Windows and Vents

Bay 108 - 1626 115 Ave. N.E.

Calgary, Alberta T3K 2E4

Phone: 403-250-9290

Fax: 403-291-0599

www.metroglass.ca

F SERIES STOREFRONT SECTION DETAILS

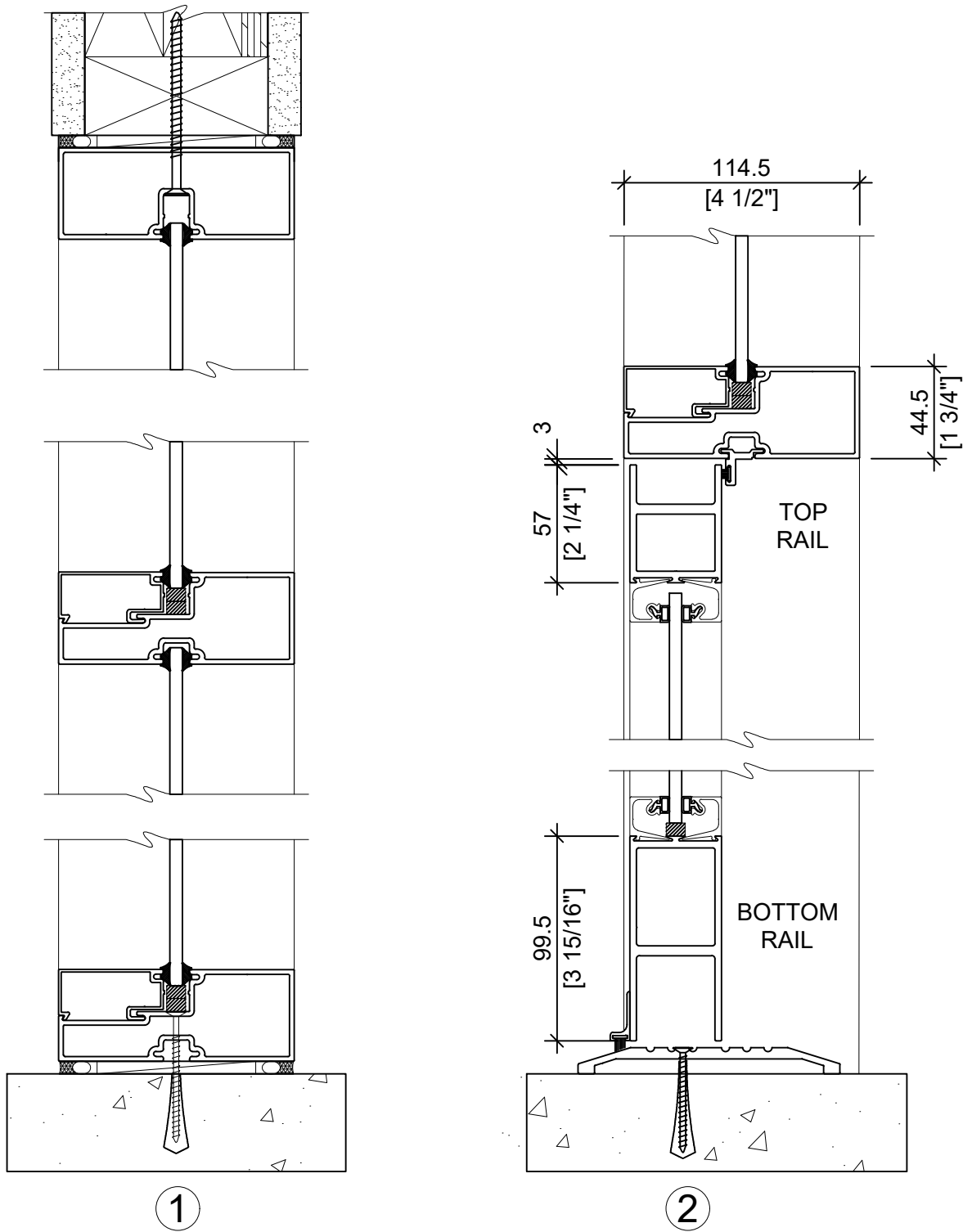

More than 50 Years of Manufacturing Innovative Aluminum Doors, Frames, Curtain Walls, Windows and Vents

Bay 108 - 1626 115 Ave. N.E. Calgary, Alberta T3K 2E4

Phone: 403-250-9290 Fax: 403-291-0599

www.metroglass.ca

F SERIES STOREFRONT PLAN DETAILS

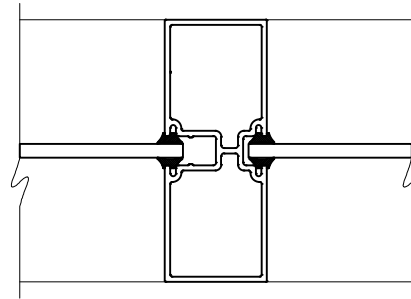

3

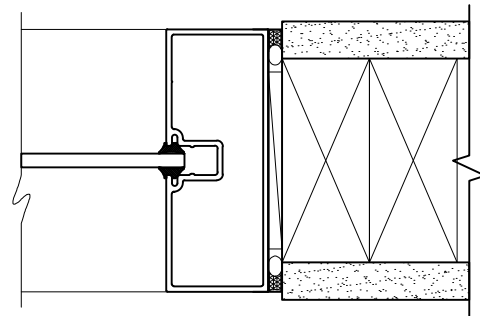
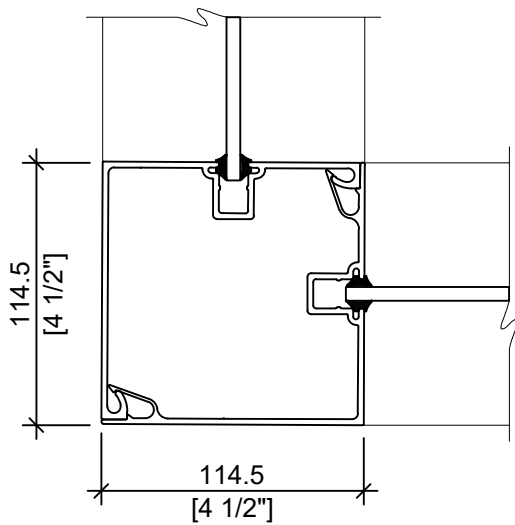

4

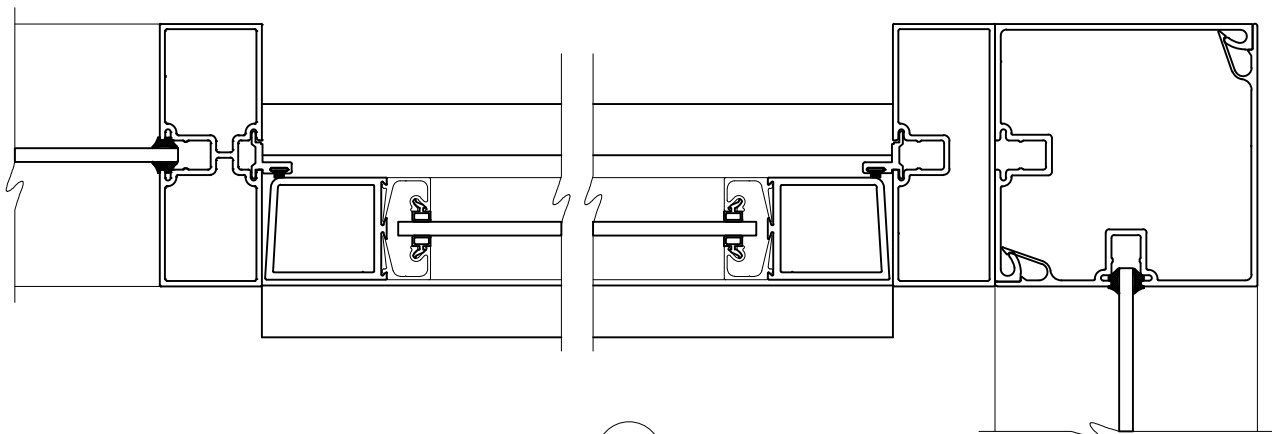

5







More than 50 Years of Manufacturing Innovative Aluminum Doors, Frames, Curtain Walls, Windows and Vents

Bay 108 - 1626 115 Ave. N.E. Calgary, Alberta T3K 2E4

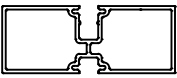
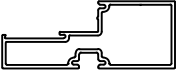
Phone: 403-250-9290 Fax: 403-291-0599

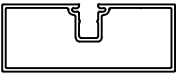
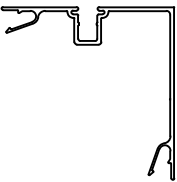
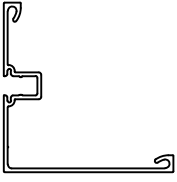
www.metroglass.ca

F SERIES STOREFRONT PARTS

CROSS SECTION	PART #	DESCRIPTION	STOCK LENGTH	CLEAR ANODIZED	BRONZE ANODIZED	BLACK ANODIZED
	F1	1 3/4" X 4 1/2" MULLION (44.5mm X 114.3mm)	7.315 m	✓	✓	✓
	F2	1 3/4" X 4 1/2" HORIZONTAL (44.5mm X 114.3mm)	4.6 m	✓	✓	✓
	F4	HORIZONTAL STOP	7.315 m	✓	✓	✓
	F5	1 3/4" X 4 1/2" MULLION (44.5mm X 114.3mm)	7.315 m	✓	✓	✓
	F6	FEMALE CORNER MULLION	6 m	✓	✓	✓
	F7	MALE CORNER MULLION	6 m	✓	✓	✓
	F8	F SERIES DOOR STOP	6.70 m	✓	✓	✓
	F10	SHEAR BLOCK	7.315 m	MILL FINISH		
	F11	SHEAR BLOCK		MILL FINISH		
		GLAZING SPLINE WEDGE GASKET AVAILABLE THICKNESS .090 - .120 - .170	500 ft ROLL			

More than 50 Years of Manufacturing Innovative Aluminum Doors, Frames, Curtain Walls, Windows and Vents

Bay 108 - 1626 115 Ave. N.E. Calgary, Alberta T3K 2E4

Phone: 403-250-9290 Fax: 403-291-0599

www.metroglass.ca

F SERIES STOREFRONT WIND LOAD CHART

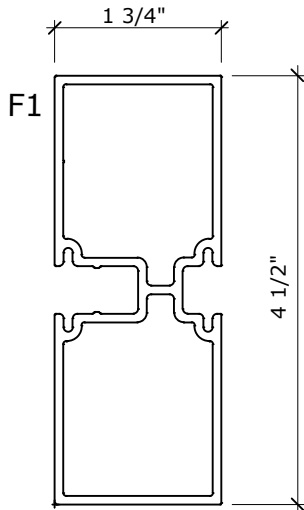

$I_{x-x} = 2.53 \text{ IN}^4$
 $S_{x-x} = 1.126 \text{ IN}^3$

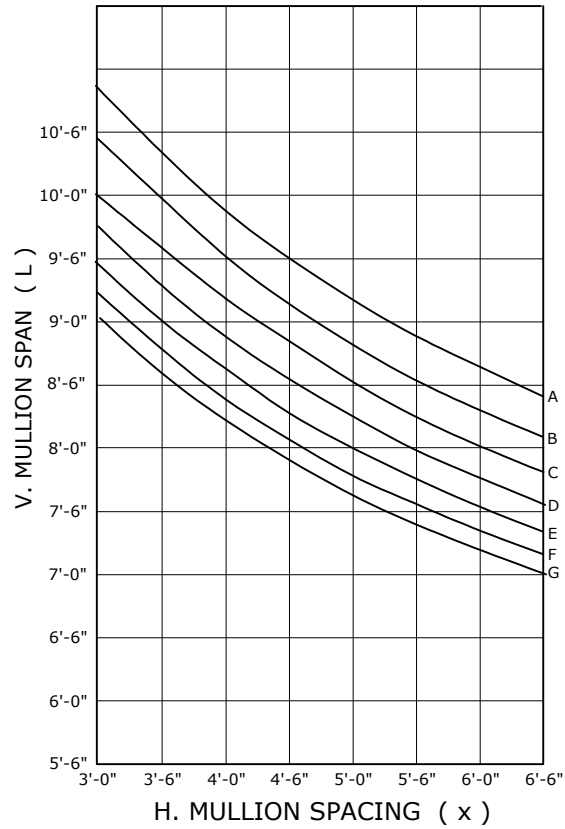

- A = 20.0 PSF
- B = 22.5 PSF
- C = 25.0 PSF
- D = 27.5 PSF
- E = 30.0 PSF
- F = 32.5 PSF
- G = 35.0 PSF

DEFLECTION = $L / 175$